

The Assembly Work Instruction

装配作业指导书

8.0mm Surlok Plus Right Angle Plug Connector

8.0mm Surlok+ 90度插头连接器

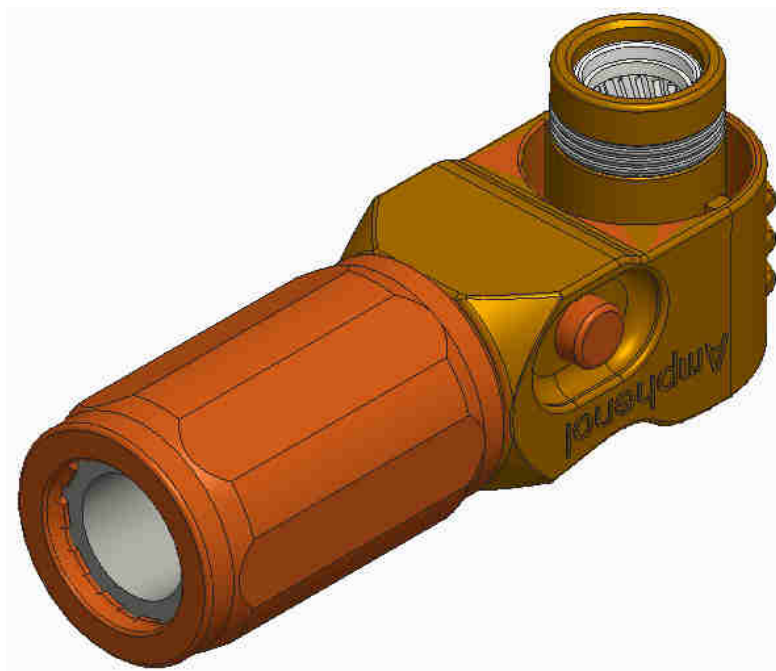

Part 1: Package contents

第一部分：包装清单

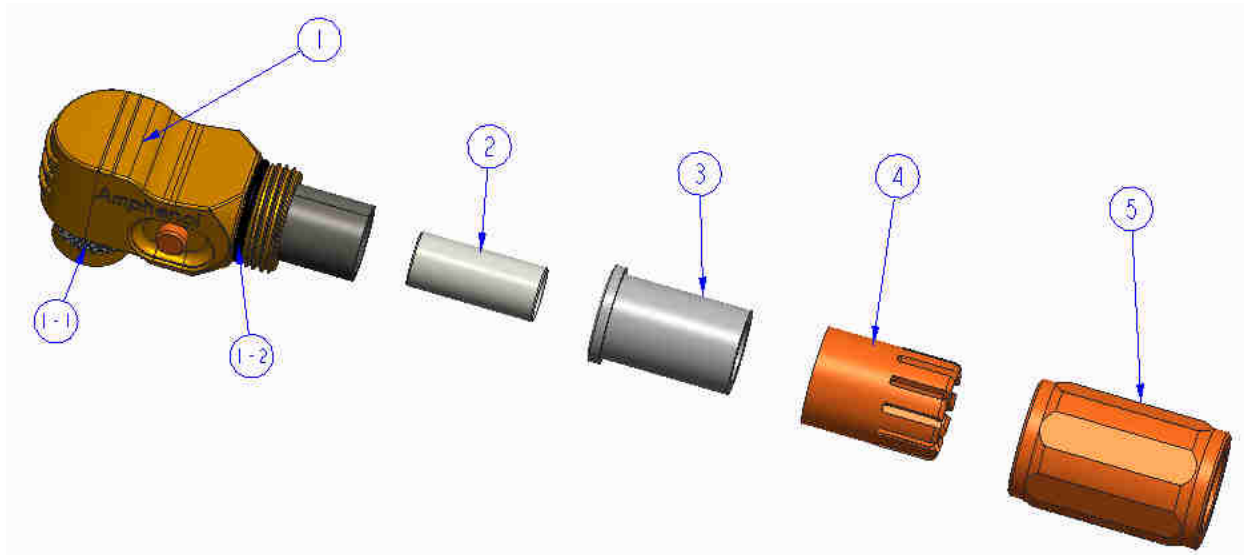

① : Connector Body 连接器本体

1-1: Barrel sealing (Not included when no sealing requirement)

前密封圈 (无防水要求时不提供此零件)

1-2: O-Ring (Not included when no sealing requirement)

后密封圈 (无防水要求时不提供此零件)

② : Barrel (Only for cable size 25mm²&35mm²)

套筒 (当线材规格为25mm²和35mm²时使用此套筒)

③ : Grommet (Not included when no sealing requirement)

橡胶密封圈 (无防水要求时不提供此零件)

④ : Cable gland 密封压盖

Apply for 25&35mm² cable with sealing requirement (有防水要求时此零件可用于25&35mm²线材)

Apply for 25&35&50mm² cable with no sealing requirement (无防水要求时均使用此零件)

⑤ : Back Shell 后壳

Part 2: Plug assembly

第二部分：插头组装

Step 1: Wire cutting and stripping (Apply for 25mm² & 35mm² & 50 mm² Cable)

步骤1：线的裁剪和剥皮（适用于25mm²和35mm²及50mm²线材）

Stripping conductor: 20±1mm

剥导体长度：20±1mm

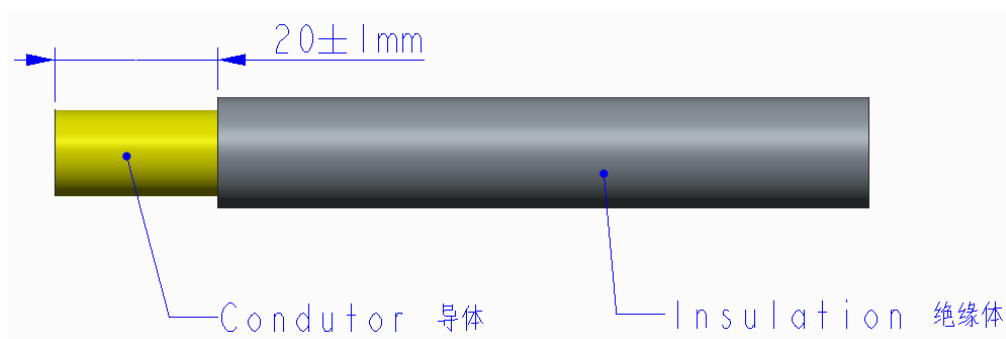

Step 2: Un-assemble item 2&3 & 4&5 over the cable as shown

Note: When 25 mm² & 35mm² cable to be used, put the barrel and then the cable conductor.

步骤2：如下所示,将套筒和橡胶密封圈和密封压盖和后壳套在线材上

备注：当使用25 mm²和35mm²线材时，将套筒装入线材导体部分

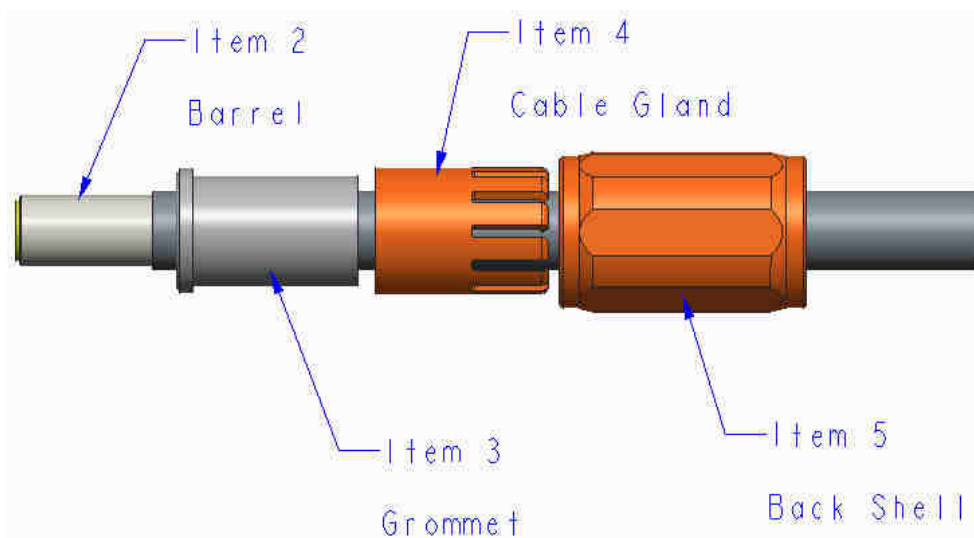

Step 3: Put the cable conductor into the lug

步骤3: 将线材导体部分插入线耳中

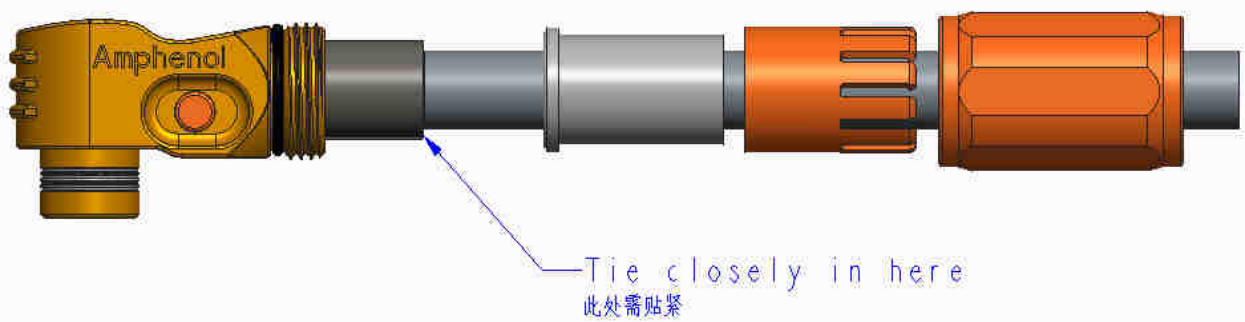

Step 4: Crimping the lug as shown

步骤4: 如图所示将线耳压接到线材导体部分

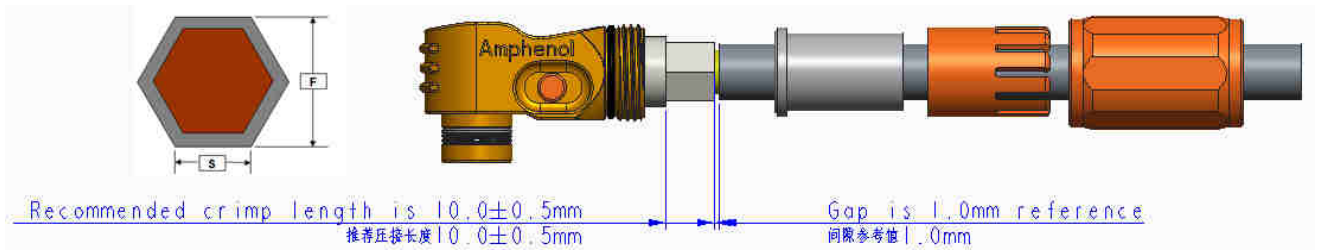

Cable size 线材尺寸	Recommended crimp length of Side S 推荐压接边长度S	Recommended crimp dist across Flats F 推荐压接平面距离F	Cable pullout force 线材压接拔出力
25 mm ²	7.0mm	10.6mm	1200N Min.
35 mm ²			1300N Min.
50 mm ²			1600N Min.

Recommended crimping tool: Manual hydraulic crimping

推荐压接工具: 手动液压压接钳

Die: 50 mm²

压模: 50 mm²



Step 5: Install grommet and cable gland and back shell

步骤5: 组装橡胶密封圈和密封压盖和后壳

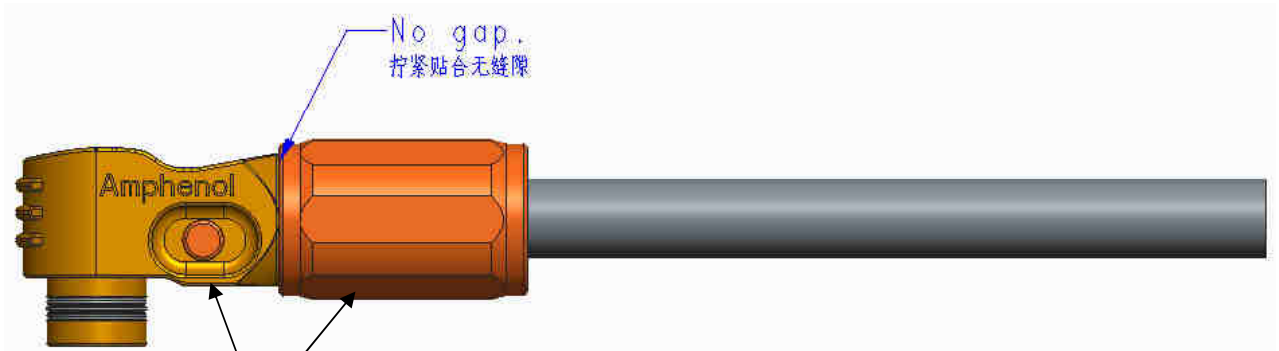
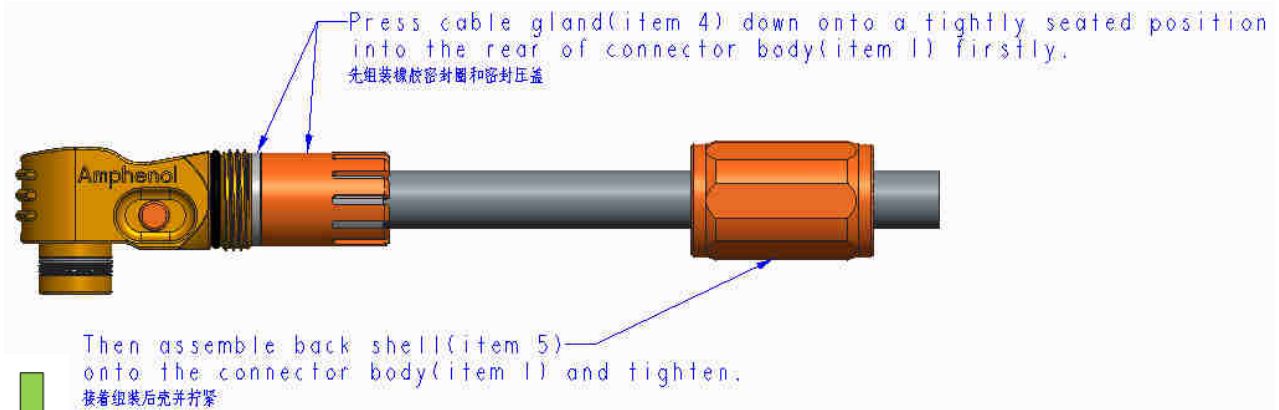

Tighten back shell to the indicated location shown as picture above by hand or tool.

通过手或工具拧紧外壳至上图所示的位置。

The recommended torque as below:

推荐扭矩如下：

25mm² : 1.0~1.2N.m

35mm² : 1.0~1.2N.m

50mm² : 1.2~1.5N.m