

Copying of this document and giving it to others and the use or communication of the contents thereof, are forbidden without express authority. Offenders are liable to the payment of damages. All rights are reserved in the event of the grant of a patent or the registration of the utility model or design.

Teilenummer <i>part number</i>	Anschluss- querschnitt <i>terminal cross-section</i>	AWG <i>AWG</i>	Crimpzange <i>crimp tool</i>	Crimpbacken <i>crimping dies</i>
N 02 060 6117 001 	16 mm ²	6	EK 12042 (Klauke) oder / or AHPW 400C (Neko)	TE 0600 062
N 02 060 6114 001 	25 mm ²	4		TE 0600 042
N 02 060 6118 001 	35 mm ²	2		TE 0600 022

Steckzyklen / *mating cycles*: ≥500
 Material / *material*: CuNi + PA-GF
 Oberflächenbeschichtung / *surface plating*: Ag (silver)
 Abisolierlänge / *stripping length*: 17 mm

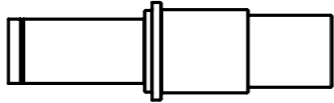
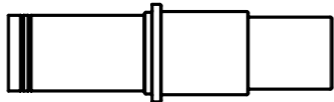
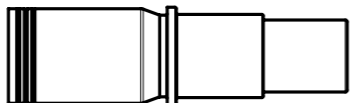
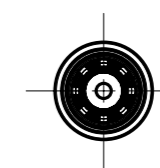
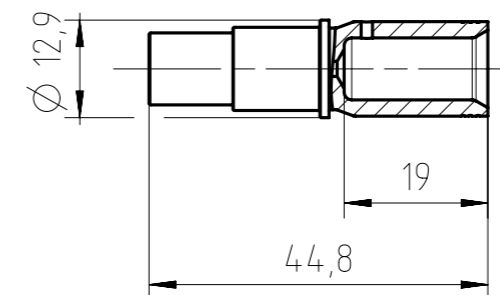
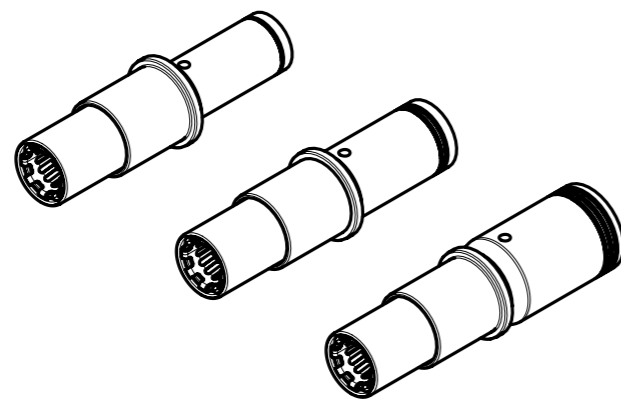
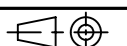

Gewicht (errechnet) / <i>Calc WT</i> : 17,6 g		Zul. Abw./ <i>Tolerances</i> :	Maßstab / <i>Scale</i> : 1:1	A3	
Prüfmaß / <i>Testdimension</i>		ISO 2768-mH	CUSTOMER DRAWING		
Teileindex / <i>Partindexnumber</i> :		DIN / ISO 13715	Buchsenkontakt 6mm RADSOK <i>socket contact 6 mm RADSOK</i>		
Bagatelle <i>change</i> :					
Gez. / <i>Drawn</i>	21.02.2019	Blatt / <i>Sheet</i> 1			
Status	PWOELFFLE				
Gepr. / <i>Checked</i>	01.03.2019	M N 02 060 611X 001			
	MGRIMM				
Amphenol Tuchel Industrial GmbH		Ers. f. / <i>Replacement for</i> :		1 Bl.	
01	201900103	22.02.2019	PWOLF		
Index	Änderung / <i>Description</i>	Datum / <i>Date</i>	Name		

Weitergabe sowie Vervielfältigung dieser Unterlage, Verwertung und Mitteilung ihres Inhalts nicht gestattet, soweit nicht ausdrücklich zugestanden. Zuwiderhandlungen verpflichten zu Schadensersatz. Alle Rechte für den Fall der Patenterteilung oder Gebrauchsmuster-Eintragung vorbehalten.

FAI2019-000571
NXM-V01