

Lieferzustand:  
delivery condition:

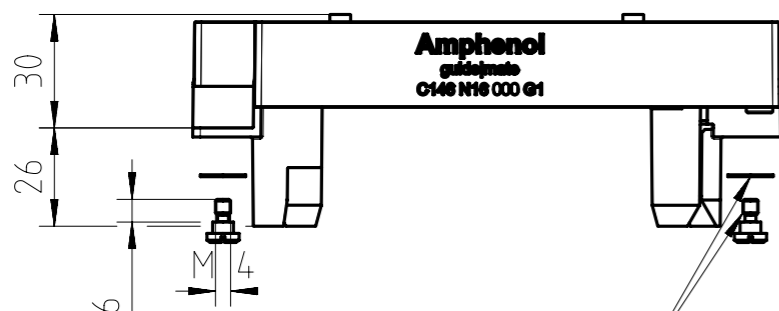

Schrauben und Scheiben lose beigelegt  
screws and washer attached loose

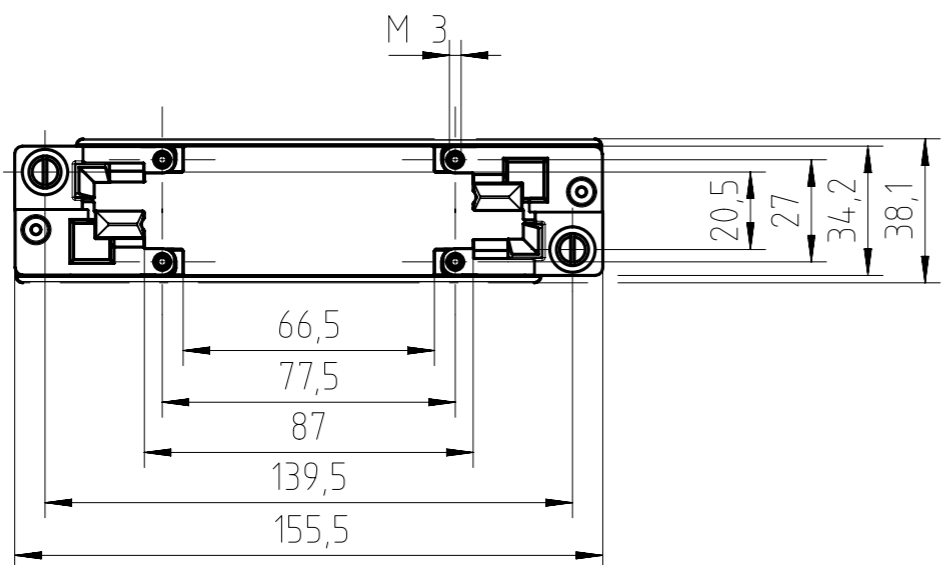
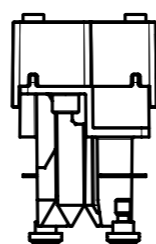

Hinweise zum Einbau siehe Seite 2  
information for assembly see page 2

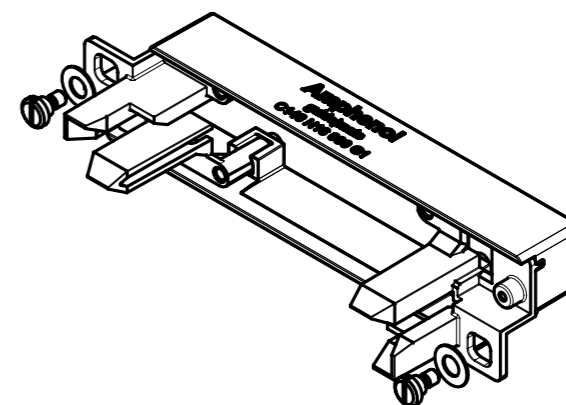

### Characteristics

General Characteristics	Standard	Value
size		E16
tolerance compensation		single guidemate: 1,5 mm in each direction mating pair equipped with guidemates: 3 mm in each direction
panel cut out		see page 2
Climatical Characteristics	Standard	Value
climatic category	IEC 60068-1	40 / 100 / 21
upper temperature	IEC 60512-11-9	+100 °C
lower temperature	IEC 60512-11-10	-40 °C
Mechanical Characteristics	Standard	Value
mechanical operation	IEC 60512-9-1	≥500 mating cycles
tightening torque of M4 screws		2,5 - 2,9 Nm
Materials	Standard	Value
guidemate frame		GD-Zn

Gewicht (errechnet) / Calc WT: 0,216 kg		Zul. Abw./Tolerances:		Maßstab / Scale: 1:2		A3			
Prüfmaß / Testdimension		ISO 2768-m		DIN / ISO 13715		CUSTOMER DRAWING			
Teileindex / Partindexnumber:									
Bagatelle change:						guidemate E16 guidemate E16			
		Gez. 02.10.2013				M C146 N16 000 G1			
		Drawn DSC-MIG							
		Status Released				Blatt / Sheet 1			
		Gepr. 10.03.2020							
		Checked MGRIMM				2 Bl.			
04 202000122 10.03.2020 PWÖLF		Amphenol Tuchel				Ers. f. / Replacement for: M-C146 N16 000 G1 Rev.02			
03 201800253 12.06.2018 PWÖLF		Industrial GmbH							
Index		Änderung / Description		Datum / Date		Name			

Alle technischen Daten wurden unter Laborbedingungen ermittelt und können im Praxisbetrieb abweichen. Es handelt sich bei den Angaben weder um Beschaffenheits- noch um Haltbarkeitsgarantien. Beim Gebrauch von Fremdkontakten wird für abweichende Eigenschaften keine Haftung übernommen. All technical data have been measured in a laboratory environment and can be different during practical usage of the product. Any product information is for descriptive usage only and not legally binding, particularly the information does not constitute or provide any legal guarantees ("Beschaffenheitsgarantie" or "Haltbarkeitsgarantie"). By using contacts from other manufacturers the liability of the part is not assumed

Copying of this document and giving it to others and the use or communication of the contents thereof, are forbidden without express authority. Offenders are liable to the payment of damages. All rights are reserved in the event of the grant of a patent or the registration of the utility model or design.

Weitergabe sowie Vervielfältigung dieser Unterlage, Verwertung und Mitteilung ihres Inhalts nicht gestattet, soweit nicht ausdrücklich zugestanden. Zuwiderhandlungen verpflichten zu Schadenersatz. Alle Rechte für den Fall der Patenterteilung oder Gebrauchsmuster-Eintragung vorbehalten.

FAI2020-000857  
NXM-V05

Hinweise zum Einbau / information for assembly

Montageausschnitt:  
panel cut out:

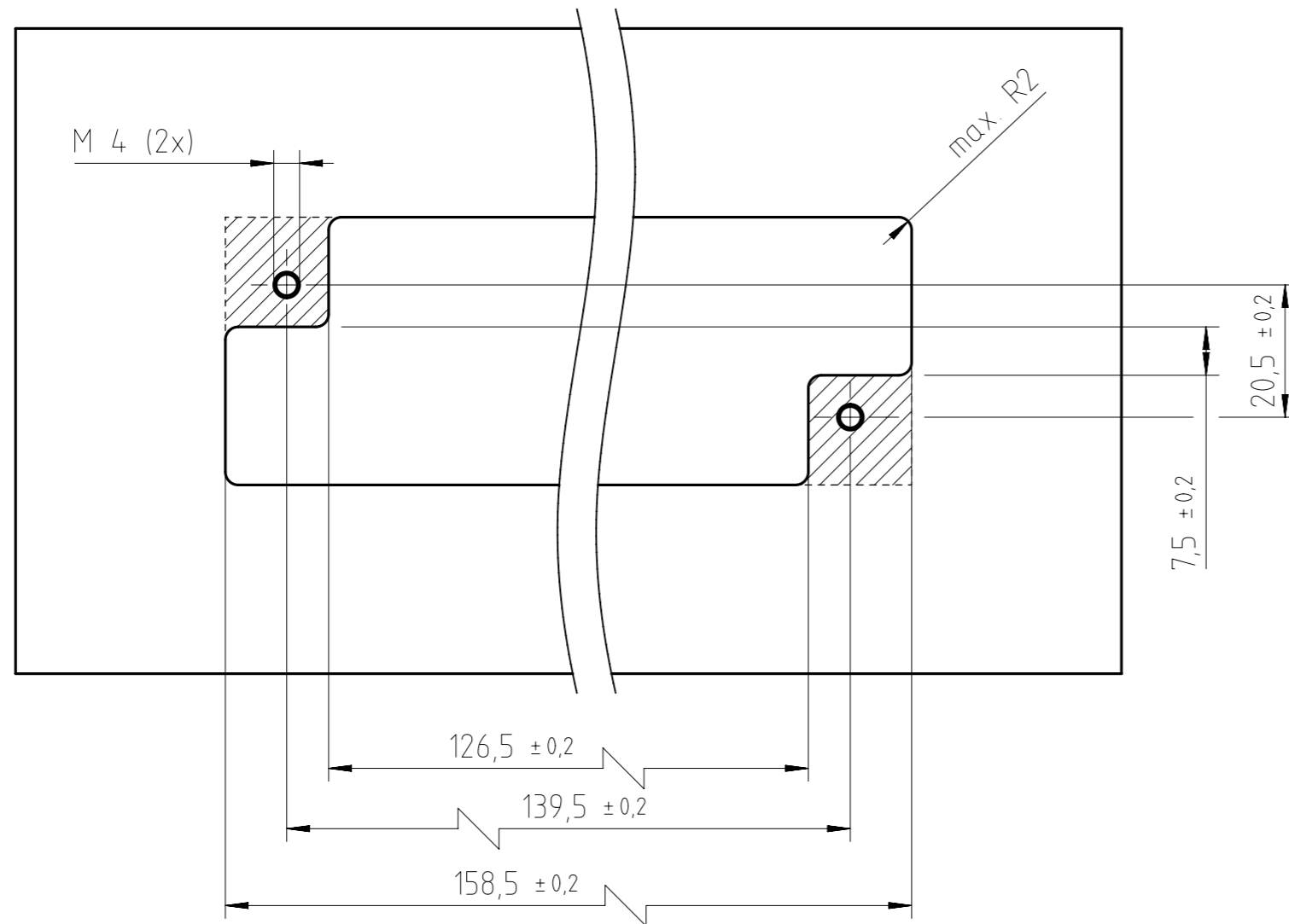

Einbauzustand:  
assembly condition:

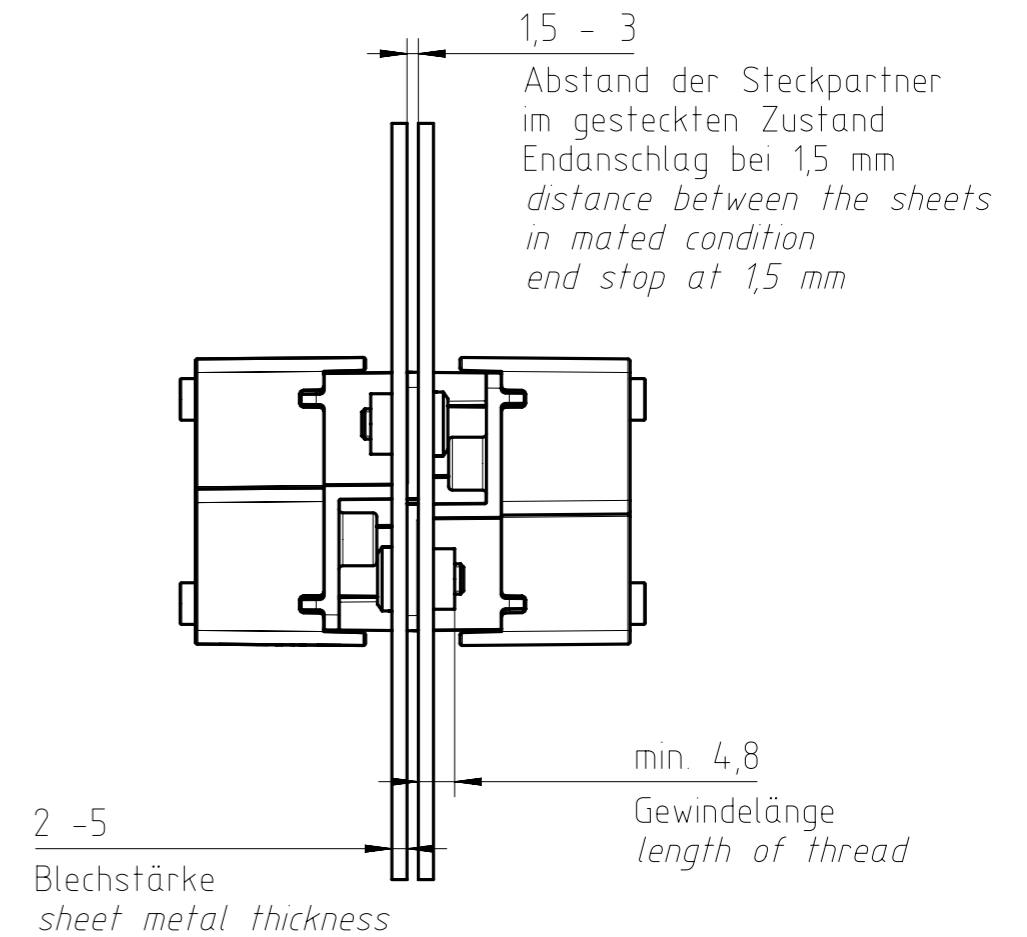

zulässige Materialien für Montageblech: Stahl, Al-Legierungen ausgehärtet  
approved materials for sheet metal: steel, aluminium-alloys hardened

Gewicht (errechnet) / Calc WT: 0,216 kg		Zul. Abw./Tolerances:		Maßstab / Scale: 1:2	A3	
Prüfmaß / Testdimension		ISO 2768-m		CUSTOMER DRAWING		
Teileindex / Partindexnumber:				guidelmate E16		
Bagatelle change:		Gez. 02.10.2013		guidelmate E16		
		Drawn DSC-MIG				
		Status Released				
		Gepr. 10.03.2020				
		Checked MGRIMM				
		<b>Amphenol Tuchel Industrial GmbH</b>		M C146 N16 000 G1		Blatt / Sheet 2
04	202000122	10.03.2020	PWÖLF			2 Bl.
03	201800253	12.06.2018	PWÖLF			
Index	Änderung / Description	Datum / Date	Name	Ers. f. / Replacement for: M-C146 N16 000 G1 Rev.02		

Coping of this document and giving it to others and the use or communication of the contents thereof, are forbidden without express authority. Offenders are liable to the payment of damages. All rights are reserved in the event of the grant of a patent or the registration of the utility model or design.  
 Weitergabe sowie Vervielfältigung dieser Unterlage, Verwertung und Mitteilung ihres Inhalts nicht gestattet, soweit nicht ausdrücklich zugestanden. Zuwiderhandlungen verpflichten zu Schadenersatz. Alle Rechte für den Fall der Patenterteilung oder Gebrauchsmuster-Eintragung vorbehalten.

FAI2020-000857  
NXM-V05