

Teilenummer part number	Anschluss- querschnitt terminal cross-section	AWG AWG	Durchmesser D diameter D	Merkmal mark	Gewicht weight	Crimpzange crimp tool	Crimpbacken crimping dies
N 01 100 5099 001 	25 mm ²	4	∅ 10,0 mm	-	28 g	EK 12042 (Klauke) oder / or AHPW 400C (Neko)	TE 0600 042
N 01 100 6000 001 	35 mm ²	2	∅ 12,5 mm	1 notch	28 g		TE 0600 022
N 01 100 6001 001 	50 mm ²	1	∅ 14,5 mm	2 notches	36 g		TE 0500 103
N 01 100 6002 001 	70 mm ²	00	∅ 16,5 mm	3 notches	38 g		TE 0500 201
N 01 100 6003 001 	95 mm ²	000	∅ 19,0 mm	4 notches	51 g		TE 0500 301

General Characteristics	Standard	Value
contacts termination technique		crimp
contacts type		machined contacts
cable type	IEC 60228	class 5 (fine-strand)
stripping length		16,5 ⁺² ₋₀
Electrical Characteristics	Standard	Value
rated current T _{amb} = 40 °C		depending on contact insert
current carrying capacity	IEC 60512-5-2	see derating curve
contact resistance	IEC 60512-2-1	≤ 5 mΩ
Climatical Characteristics	Standard	Value
operating temperature	IEC 60068-1	-40 - +125 °C
Mechanical Characteristics	Standard	Value
mechanical operation	IEC 60512-9-1	≥500 mating cycles
mating/unmating force (in new condition)	IEC 60512-16-5	≤80 N
Materials	Standard	Value
contact material		copper alloy
contact plating contact area		Ag (silver)
contact plating termination area		
touch protection material		PA-GF
touch protection flammability	UL 94	V-0

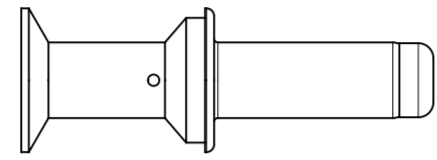
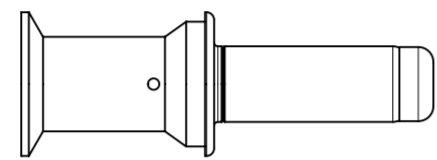
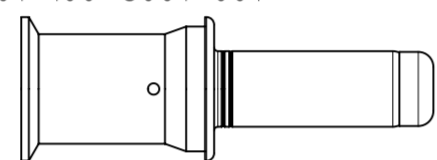
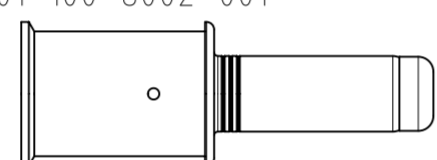
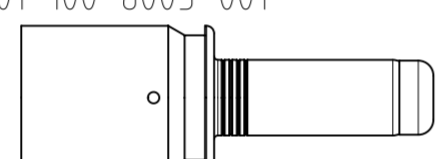
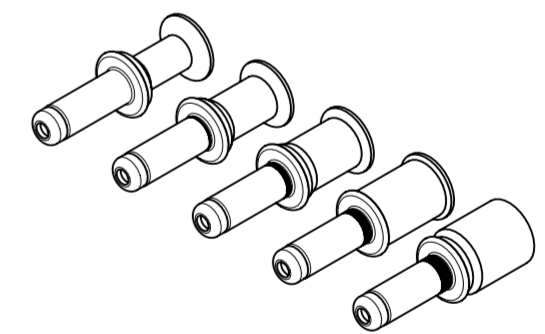
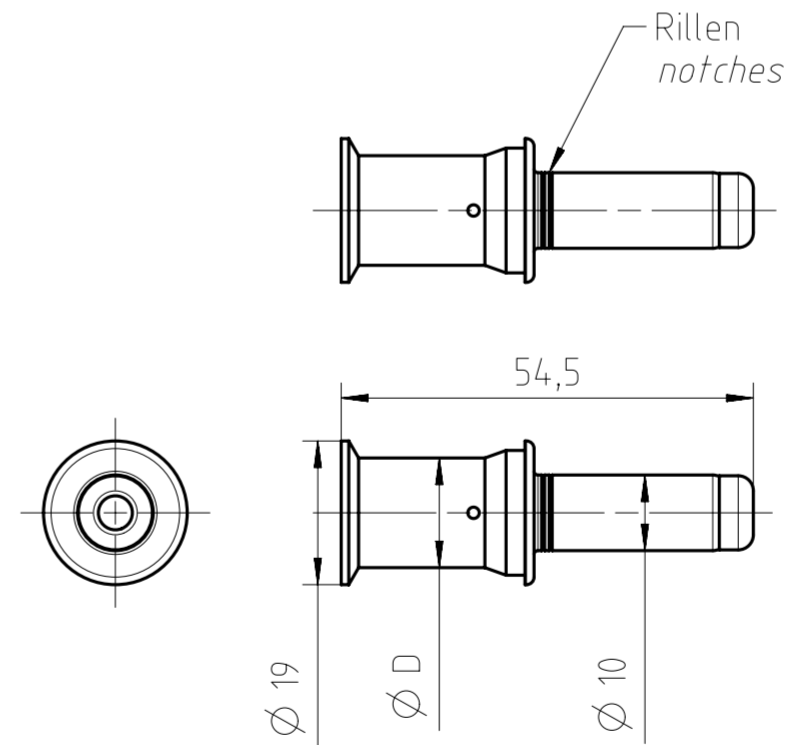

Alle technischen Daten wurden unter Laborbedingungen ermittelt und können im Praxisbetrieb abweichen. Es handelt sich bei den Angaben weder um Beschaffenheits- noch um Haltbarkeitsgarantien. All technical data have been measured in a laboratory environment and can be different during practical usage of the product. Any product information is for descriptive usage only and not legally binding, particularly the information does not constitute or provide any legal guarantees ("Beschaffenheitsgarantie" or "Haltbarkeitsgarantie").

Weitergabe sowie Vervielfältigung dieser Unterlage, Verwertung und Mitteilung ihres Inhalts nicht gestattet, soweit nicht ausdrücklich zugestanden. Zuwiderhandlungen verpflichten zu Schadenersatz. Alle Rechte für den Fall der Patenterteilung oder Gebrauchsmuster-Eintragung vorbehalten.

Copying of this document and giving it to others and the use or communication of the contents thereof, are forbidden without express authority. Offenders are liable to the payment of damages. All rights are reserved in the event of the grant of a patent or the registration of the utility model or design.

Gewicht (errechnet) / Calc. WT.: 43,8 g	Zul. Abw./Tolerances:	Maßstab / Scale: 1:1 (1:2)	A2	
Prüfmaß / Testdimension	ISO 2768-m	CUSTOMER DRAWING		
Teilindex / Partindexnumber:	DIN / ISO 13715	Stiftkontakt 95mm ² pin contacts 10 mm		
Bagatelle change:	Gez. 09.05.2017 Drawn: PWOLFFLE Status: Released Gepr. 14.12.2021 Checked: MBERTSCH	Amphenol Tuchel Industrial GmbH		
04 202000166 25.10.2021 PWOLFF	M N 01 100 X0XX 001			Blatt / Sheet 1
03 202100073 22.04.2021 PWOLFF	Ers. f. / Replacement for:			1 Bl.
02 201700316 16.08.2017 PWOLFF				
01 201700151 10.05.2017 PWOLFF				
Index	Änderung / Description	Datum / Date	Name	

FAI2021-004788