



Find out more about our products on:
www.amphenol-industrial.de

Kontaktgrößen contact sizes	Anschlussquerschnitt terminal cross-section	AWG AWG	Isolationsdurchmesser diameter cable insulation	Beschichtung contact plating	Höhe H height H	Gewicht weight	Crimpzange crimp tool	Crimpbacken crimping dies	Kontaktaufnahme contact locator
N 01 010 0130 2 	0,09-0,25 mm ²	28-24	Ø 0,7- Ø 1,6	Au (gold) crimp area: Sn (tin)	1,5	0,1 g	TA 0000 oder / or TA 0500 oder / or EK 15/50 ML (Klauke)	TA 0000 501	TA 0001 017 0001
N 01 010 0131 2 	0,25-0,5 mm ²	24-20	Ø 1,6- Ø 2,0		2,0				

vereinzelte Kontakte im Beutel /
single contacts in PE bag

Bestellnummer order number	Lieferform delivery condition
VN01 010 0130 2	100 contacts
VN01 010 0131 2	

Kontakte am Band für Crimpzange /
contact on reel for manual crimping tool

Bestellnummer order number	Lieferform delivery condition
ZN01 010 0130 2	350 contacts
ZN01 010 0131 2	

Kontakte am Band für Crimpmaschine Zuführung links /
contact on reel for crimping machine infeed left

Bestellnummer order number	Lieferform delivery condition
TN01 010 0130 2	2000 contacts
TN01 010 0131 2	

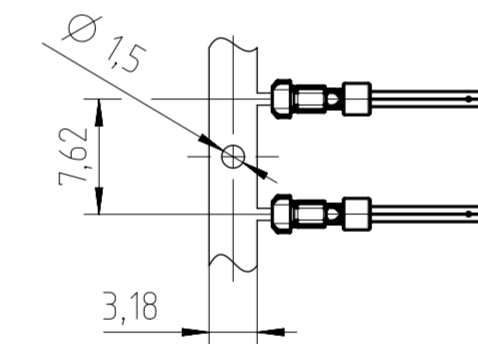
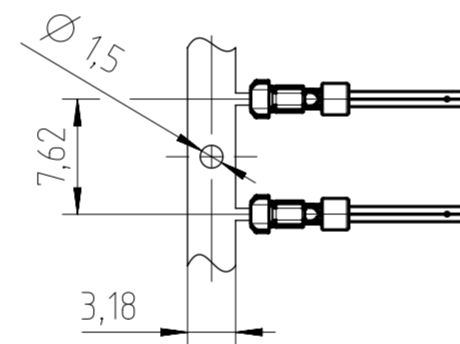
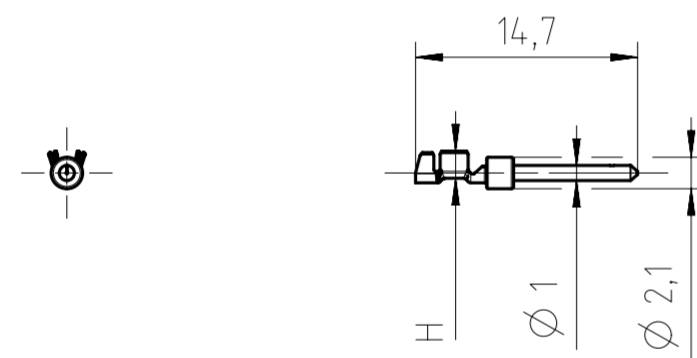

General Characteristics	Standard	Value
contacts termination technique		crimp
contacts type		stamped contacts
cable type	IEC 60228	class 5 (fine-strand)
stripping length		2,3 ⁺¹ ₋₀
Electrical Characteristics	Standard	Value
rated current T _{amb} = 40 °C		depending on contact insert
current carrying capacity	IEC 60512-5-2	see derating curve
contact resistance	IEC 60512-2-1	≤ 5 mΩ
Climatical Characteristics	Standard	Value
operating temperature	IEC 60068-1	-40 - +125 °C
Mechanical Characteristics	Standard	Value
mechanical operation	IEC 60512-9-1	≥10000 mating cycles
mating/unmating force (in new condition)	IEC 60512-16-5	≤3 N
Materials	Standard	Value
contact material		copper alloy
contact plating contact area		Au (gold)
contact plating termination area		Sn (tin)



Weitergabe sowie Vervielfältigung dieser Unterlage, Verwertung und Mitteilung ihres Inhalts nicht gestattet, soweit nicht ausdrücklich zugestanden. Zuwiderhandlungen verpflichten zu Schadenersatz. Alle Rechte für den Fall der Patenterteilung oder Gebrauchsmuster-Eintragung vorbehalten.

Copying of this document and giving it to others and the use or communication of the contents thereof, are forbidden without express authority. Offenders are liable to the payment of damages. All rights are reserved in the event of the grant of a patent or the registration of the utility model or design.

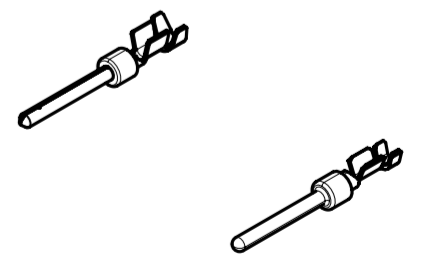

Gewicht (errechnet) / Calc. WT.:	Zul. Abw./Tolerances:	Maßstab / Scale: 2:1 (1:1)	A2
Prüfmaß / Testdimension	ISO 2768-m	CUSTOMER DRAWING	
Teilindex / Partindexnumber:	DIN / ISO 13715	Stiftkontakte Ø 1,0 mm pin contacts Ø 1,0 mm	
Bagatelle change:	Gez. 23.04.2021 Drawn PWOLFFLE	Blatt / Sheet 1	
	Status Released	1 Bl.	
	Gepr. 16.10.2023 Checked MBERTSCH	NXM-V01	
02 202300083 11.08.2023 PWÖLF	Amphenol Tuchel Industrial GmbH	M XN01 010 013X 2	
01 202100181 26.04.2021 PWÖLF			
Index Änderung / Description	Datum / Date	Name	Ers. f. / Replacement for: