

Find out more about our products on:  
[www.amphenol-industrial.de](http://www.amphenol-industrial.de)

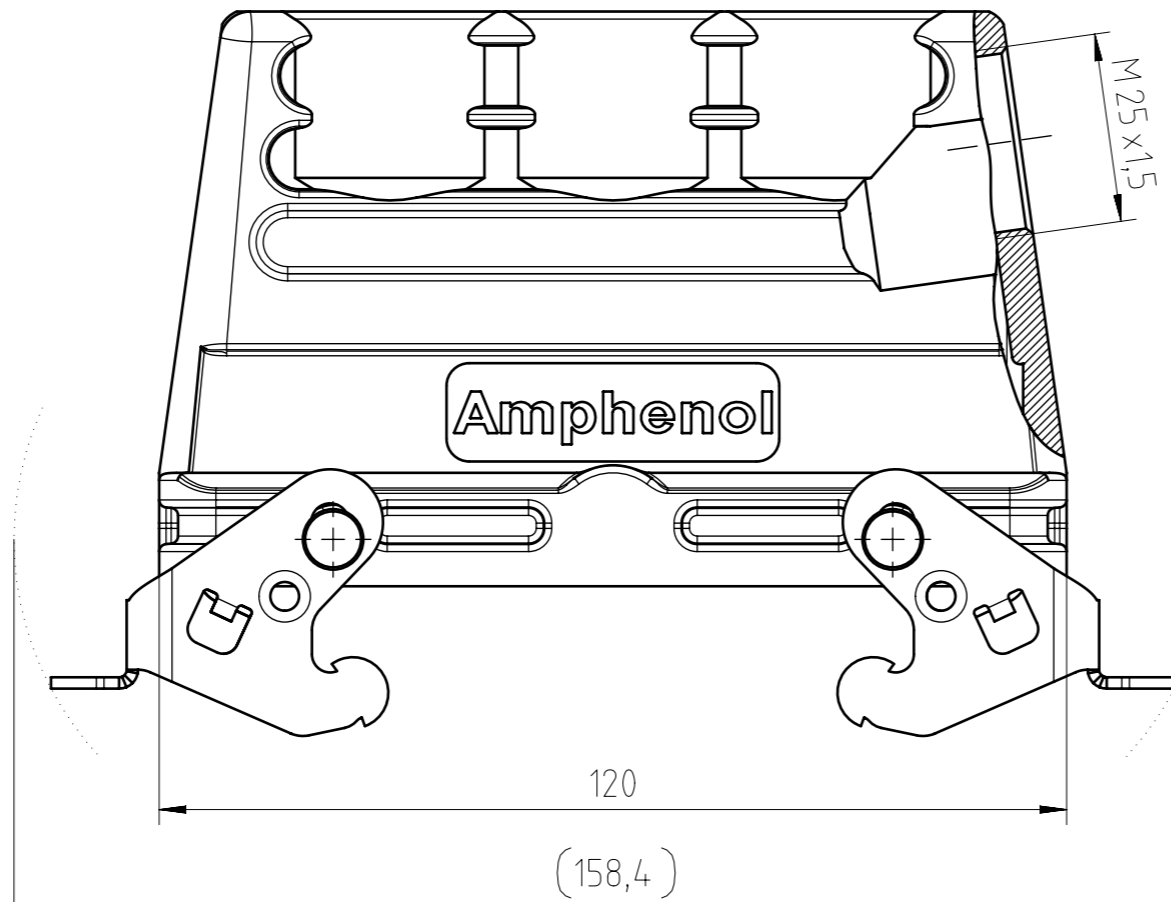
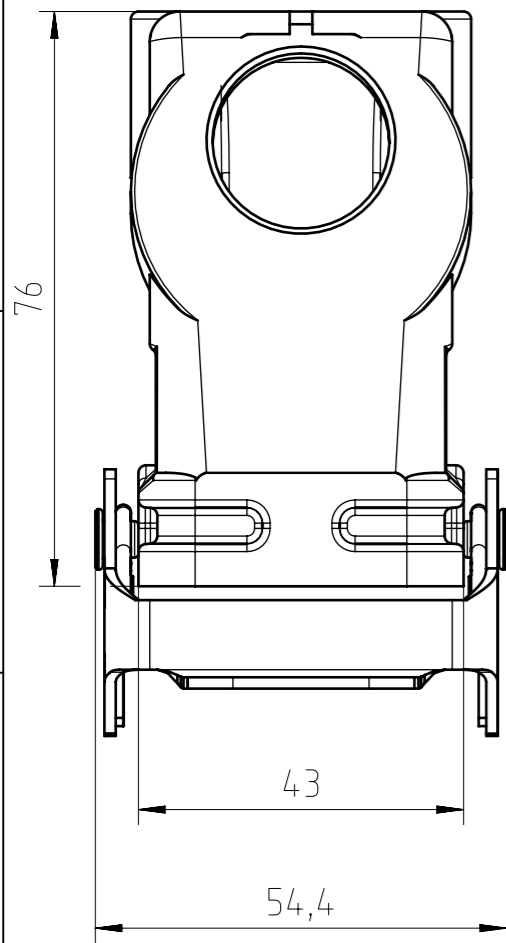
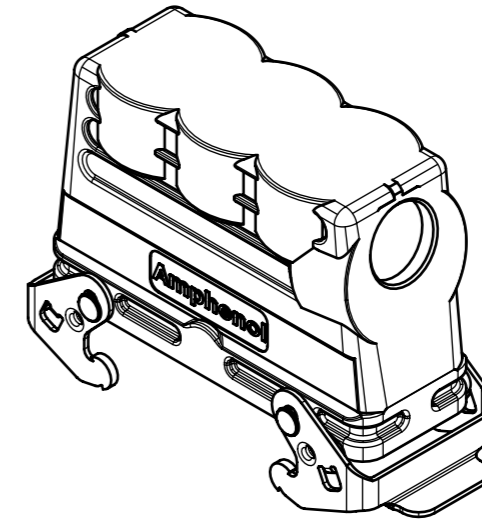
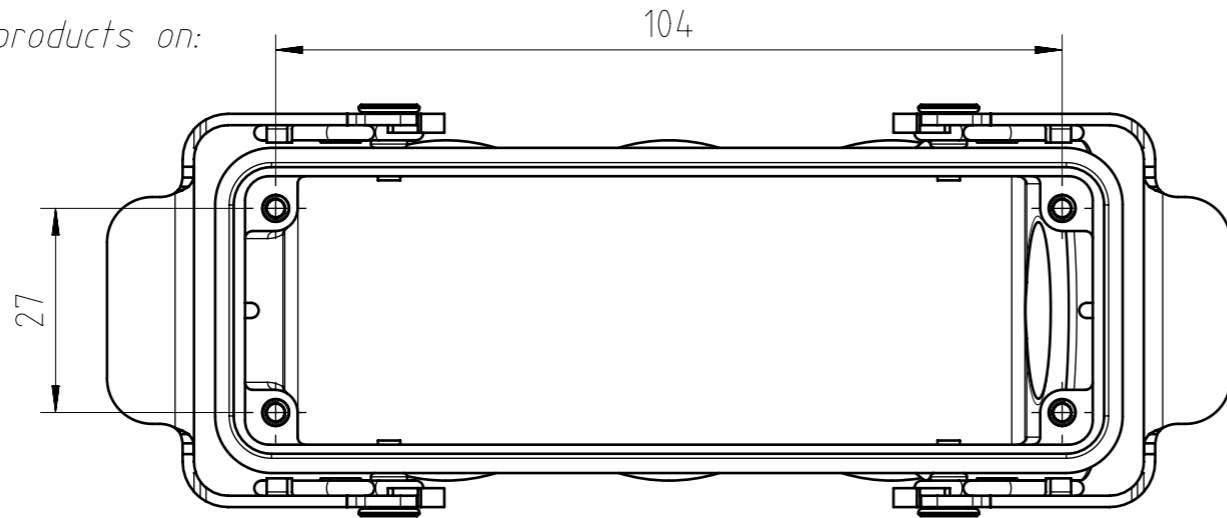

General Characteristics	Standard	Value
Type		hood
Protection class	IEC 60529	IP65 & IP66
Locking System	DIN EN 175 301-801 (DIN 43 652)	2 locking levers
Cable entry & position		M25 side
Climatical Characteristics	Standard	Value
Operating temperature	IEC 60068-1	-40°C - +100°C
Mechanical Characteristics	Standard	Value
Mechanical operation	IEC 60512-9-1	≥500 mating cycles
Materials	Value	
Housing material		Al (aluminium) alloy
Housing surface		powder coated
Housing color		grey (similar to RAL 9006)
Locking system material & surface		steel Zn-plated

Gewicht (errechnet) / Calc WT: 285,4 g		Zul. Abw./Tolerances:		Maßstab / Scale: 1:1 (1:2)	A3	
Prüfmaß / Testdimension		ISO 2768-m		CUSTOMER DRAWING		
Teileindex / Partindexnumber:		DIN / ISO 13715		Tüllengehäuse E24 M25		
Bagatelle change:		Gez. 05.05.2021		hood E24 M25		
		Drawn APN_MSEIDEL				
		Status Released				
		Gepr. 06.05.2021				
		Checked MBERTSCH				
		<b>Amphenol Tuchel Industrial GmbH</b>		Blatt / Sheet 1		
02	202100101	01.10.2021	PWÖLF	M C146 21R024 552 8		1 Bl.
Index	Änderung / Description	Datum / Date	Name	Ers. f. / Replacement for:		

Alle technischen Daten wurden unter Laborbedingungen ermittelt und können im Praxisbetrieb abweichen. Es handelt sich bei den Angaben weder um Beschaffenheits- noch um Haltbarkeitsgarantien.  
All technical data have been measured in a laboratory environment and can be different during practical usage of the product. Any product information is for descriptive usage only and not legally binding; particularly the information does not constitute or provide any legal guarantees ("Beschaffenheitsgarantie" or "Haltbarkeitsgarantie").

Copying of this document and giving it to others and the use or communication of the contents thereof, are forbidden without express authority. Offenders are liable to the payment of damages. All rights are reserved in the event of the grant of a patent or the registration of the utility model or design.  
 Weitergabe sowie Vervielfältigung dieser Unterlage, Verwertung und Mitteilung ihres Inhalts nicht gestattet, soweit nicht ausdrücklich zugestanden. Zuwiderhandlungen verpflichten zu Schadensersatz. Alle Rechte für den Fall der Patenterteilung oder Gebrauchsmuster-Eintragung vorbehalten.

FAI2021-001967  
NXM-V02